

TECHNICAL BULLETIN

TRI-FUNCTIONAL® BUSHINGS

SUBJECT: Pivot Bushing Inspection Procedure

LIT NO: B106

DATE: January 2007 REVISION: B

Periodic inspections are an important part of your air suspension maintenance routine. Of particular importance is the pivot bushing, which is housed within the beam assembly bushing tube. All such inspections should include an evaluation of all pivot bushings on the trailer.

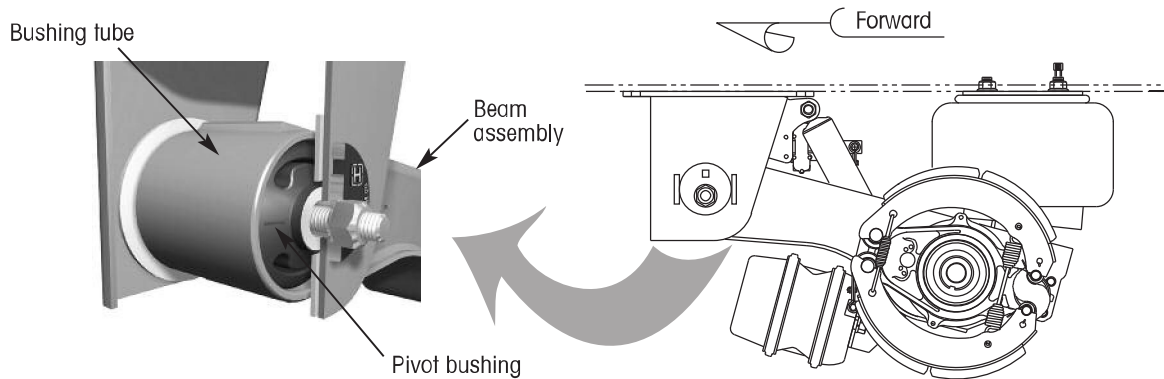

Hendrickson does not recommend disassembling the pivot connection to inspect the pivot bushing. The recommended procedure is to make a measurement as follows. On an unloaded trailer, measure from the bottom of the beam assembly to the bottom of the frame bracket as shown below.

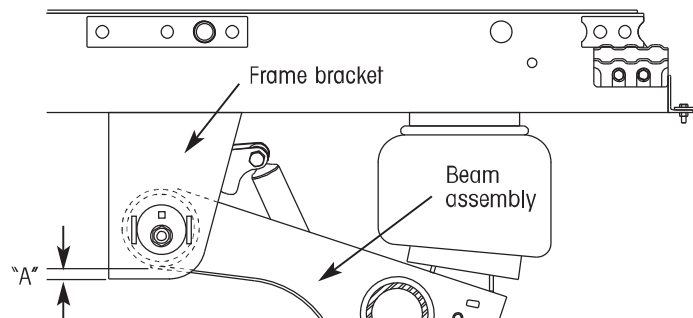

NOTE: Trailer must be unloaded.

If "A" is less than or equal to $\frac{3}{4}$ " : bushing is OK.
If "A" is greater than $\frac{3}{4}$ " : Disassemble pivot connection and check bushing. Refer to L427.

If the measured dimension is less than or equal to $\frac{3}{4}$ of an inch, the pivot bushing is OK. If the measured dimension is greater than $\frac{3}{4}$ of an inch, the pivot connection must be disassembled and the beam assembly lowered to more closely inspect the bushing. **Failure to follow this procedure will void warranty coverage.** If necessary, refer to Hendrickson publication L427 *Bushing Replacement Procedures* for pivot connection disassembly instructions. With the beam assembly lowered, Hendrickson recommends inspecting the pivot bushings, bushing tube spacers, bushing tube and interior surfaces of the frame bracket. Refer to Hendrickson publication L750 *Bushing Tube Spacer Inspection / Replacement Procedure* for inspection instructions.

Pivot bushings will typically “settle” in the vertical direction upon suspension installation. It is normal for the voids to have this “settled” appearance (illustration b) due to cargo and the weight of the trailer loading the bushing. However, cracks in the rubber extending between the void and the bushing’s inner metal or an

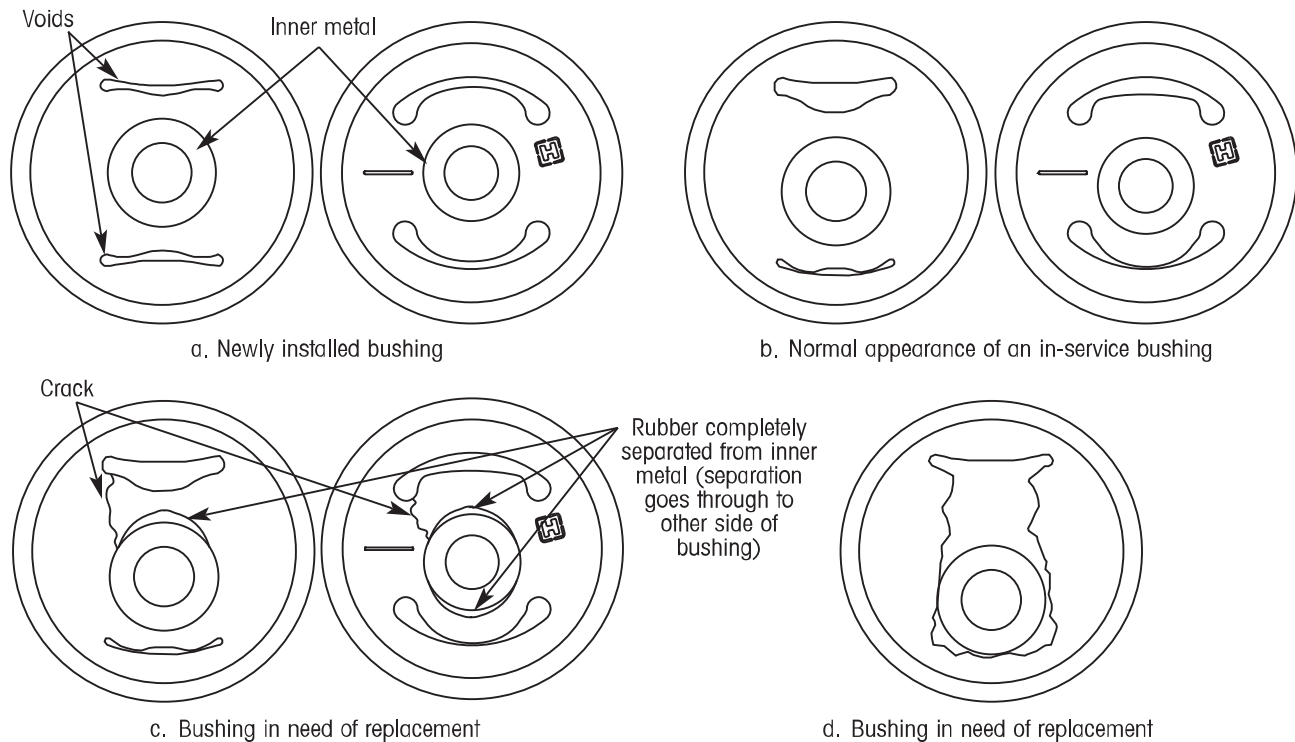

excessive amount of vertical movement (illustrations c and d) are indications that the bushing needs to be replaced. If conditions similar to c and d are found, replace the bushing. **For warranty consideration, a digital photograph of the bushing in the bushing tube is required. Take the photograph before removing the bushing from the bushing tube.** Refer to Hendrickson publication L427 *Bushing Replacement Procedures* for bushing replacement instructions. Also at this time inspect the bushing tube and interior surfaces of the frame bracket for wear. Refer to Hendrickson publication L750 *Bushing Tube Spacer Inspection / Replacement Procedure* for bushing tube and frame bracket inspection / replacement instructions.

NOTE: The practice of using a long pry bar to determine if the bushing is defective is not recommended, because a normal (nondefective) bushing will move and provide a false indication of the bushing’s condition if enough force is exerted with the pry bar.

Call the Hendrickson Technical Service department in the United States at 866-743-3247 or in Canada 800-668-5360 for additional technical support.

www.hendrickson-intl.com



Hendrickson Canada
250 Chrysler Drive, Unit #3
Brampton, ON Canada L6S 6B6
905.789.1030
Fax 905.789.1033

Trailer Commercial Vehicle Systems
2070 Industrial Place SE
Canton, OH 44707-2641 USA

866.RIDEAIR (743.3247)
330.489.0045
Fax 800.696.4416

Hendrickson Mexicana
Circuito el Marqués Sur #29
Parque Industrial El Marqués
Pob. El Colorado, Municipio El Marqués,
Querétaro, México C.P. 76246
+52 (442) 296.3600
Fax: +52 (442) 296.3601